

# CyberGage360™ 3D Scanning System

3D SCANNERS

- **Unprecedented speed, accuracy and one-button simplicity for non-contact automated 3D scanning inspection.**

Complete 360° 3D scan and inspection report in less than 3 minutes.



## High-Precision Accuracy with MRS Technology

- Generates full 360° automated scan with accuracy NIST traceable to +/- 10µm
- Incorporates CyberOptics' proprietary 3D Multi-Reflection Suppression (MRS) technology that inhibits measurement distortions for a highly accurate metrology grade scan

## Easy-to-Use with One-Button Simplicity

- Simplifies scanning with one-button automation
- Provides factory-friendly operation with minimal training
- Generates reports comparing scan data to CAD models or 'golden' example
- Speeds part program selection with Bar Code Part ID
- Programs off-line with pre-defined inspection templates
- Eliminates costly inspection gages with fixtureless design
- Offers quick and simple field recalibration

## Fast Scanning in Less than 3 Minutes

- Quickly generates a highly precise full 360° automated 3D surface scan of complex shaped parts in less than 3 minutes
- Facilitates near-production line high-volume scanning and high speed throughput

**CyberGage360 lowers Cost of Quality and shortens time-to-market by dramatically speeding up In-Process Inspection and/or Incoming/Outgoing Parts Inspections.**



**Save Time. Save Expense. Improve Yields.**



# 3D Scans – Simple as...

1

Open the door

2

Place the part

3

Press the button

Designed for use in general purpose metrology, the CyberGage360 has a range of potential industrial applications from automotive to aerospace, where high accuracy and high speed throughput are important.

## Specifications

<b>Work Volume</b>	200mm diameter x 100mm high cylinder (8" diameter x 4" high)
<b>Sensor Technology</b>	Patented MRS technology with structured blue light
<b>System Volumetric Accuracy</b>	10 μm; 0.010mm +L/10000mm (ISO 10360) See Accuracy Statement for CyberGage360 report available at <a href="http://LaserDesign.com/Products/CyberGage360">LaserDesign.com/Products/CyberGage360</a>
<b>Repeatability</b>	5 μm; 0.005mm/0.00020" See Accuracy Statement for CyberGage360 report available at <a href="http://LaserDesign.com/Products/CyberGage360">LaserDesign.com/Products/CyberGage360</a>
<b>Speed</b>	Up to 16 million points/part/ pose. Typical cycle time < 3 minutes
<b>CDRH Safety</b>	Eye safe - no protection needed
<b>System Controllers Embedded</b>	High-performance PC included
<b>Environmental Temperature</b>	Temperature ambient = 20°C +/- 3°C (68.5°F +/- 5°F) to maintain calibrated performance
<b>Operating Environment</b>	Humidity 50% +/- 30%
<b>Weight of Part</b>	2.0 kg max (4.4 lbs.)
<b>Data Output Formats</b>	STL, PLY, OBJ, ASC
<b>Electrical Requirements</b>	110-120V +/- 10% 1 phase/ 50-60hz +/- 3.5%
<b>Included with System</b>	PC controller built in, Polyworks Inspector inspection reporting software with: 1 year maintenance/updates/support, operation manual, maintenance manual, and training at factory (Minneapolis or onsite option).
<b>Warranty</b>	1-year warranty (hardware, software, parts, labor, workmanship)

## Dimensions

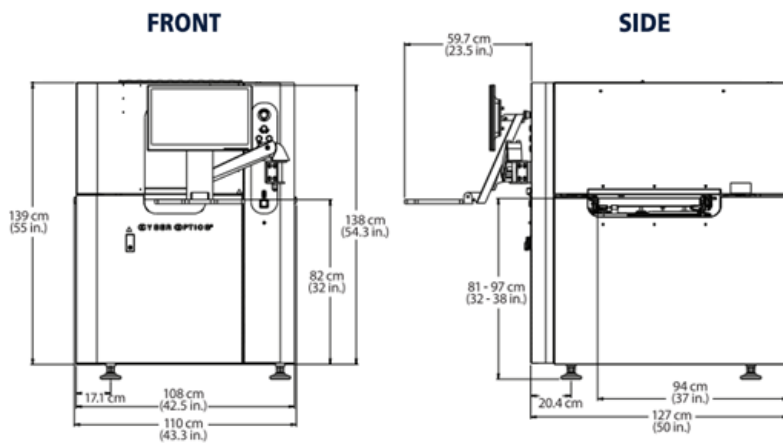

## Output Report Examples

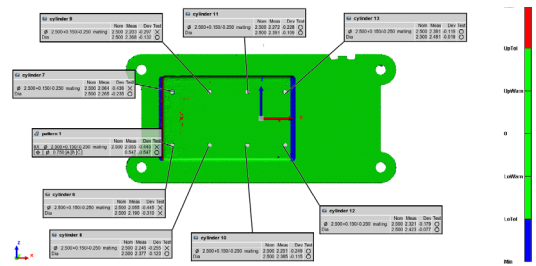

### Feature Table

Name	Control	Nom	Meas	Tol	Dev	Test	Out Tol
⊘ cylinder 6	2.500+0.150/-0.250 mating	2.500	2.055	+0.150/-0.250	-0.445	Fail	-0.195
Diameter		2.500	2.190	+0.150/-0.250	-0.310	Fail	-0.060
⊘ cylinder 7	2.500+0.150/-0.250 mating	2.500	2.064	+0.150/-0.250	-0.436	Fail	-0.186
Diameter		2.500	2.265	+0.150/-0.250	-0.235	Pass	
⊘ cylinder 8	2.500+0.150/-0.250 mating	2.500	2.245	+0.150/-0.250	-0.255	Fail	-0.005
Diameter		2.500	2.377	+0.150/-0.250	-0.123	Pass	
⊘ cylinder 9	2.500+0.150/-0.250 mating	2.500	2.203	+0.150/-0.250	-0.297	Fail	-0.047

**LASER DESIGN**  
A CyberOptics Company

Contact Laser Design today for more information  
952.884.9648 | [info@laserdesign.com](mailto:info@laserdesign.com) | [www.laserdesign.com](http://www.laserdesign.com)